

## KLAAR WOOD chair



Design by  
**Martin Pärn**  
iseasi

Rationality, neutrality and the precise aesthetic finishing of parts that characterize Klaar are qualities that never go out of date nor submit to the rapidly changing vogues. The clarity and lightness of its shape and the wide selection of materials make Klaar suitable for using in many different modern architectural contexts, offering solutions that meet different requirements. The Klaar family includes park benches for three where it is good to sit and rest one's back to gaze at the sea, single chairs that offer a moment of rest and a chance to be alone in the noise of a city square as well as seats and tables that enable the creation of picnic settings in a park.

# KLAAR WOOD chair



## FEATURES

Due to the proportions, shape and use of materials, Klaar is very ergonomic and comfortable also making it suitable to a modern architectural context as well as to a historic setting.

Different armrest configurations are possible for the chair.

A wide range of different products, including chairs, seats and tables, in the family to complement various uses and environments.

The hot-dip galvanized and powder-coated steel frame and high-quality, knot-free wooden material makes the product very resistant to weather and use.

Extery quality without compromise- harmonious design, carefully selected materials and engineering considered to the last detail.



## WOOD

The wood selection includes double layer oil coated knot-free thermo-treated ash and tropical wood. Tropical wood has no top coat.



Thermotreated ash (oiled)



Tropical wood

## METAL

The steel frame is available in hot-dip galvanized and powder coated finish. The hot-dip galvanizing is done according to ISO 1461:2009 standard.

RAL recommendation by designer:



RAL 7016 + graffiti protection



RAL 7039



RAL 9005



RAL 9010

## INSTALLATION

Freestanding on a firm base.

Anchored to a firm foundation.

Material marking in product code:  
a- thermotreated ash  
t- tropical wood

Example of code use with 2 armrest and tropical wood: KLWB60-02-t

## DIMENSIONS

Klaar Wood chair, without armrests - KLWB60

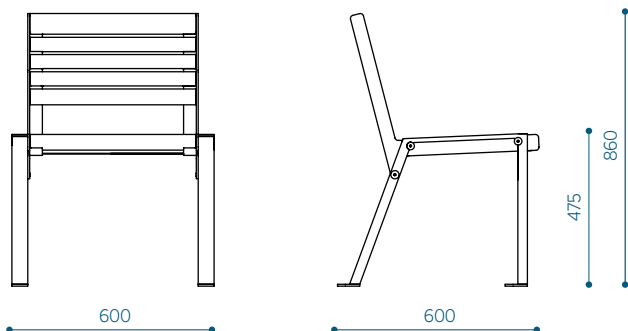

Klaar Wood chair, 2 armrests - KLWB60-02

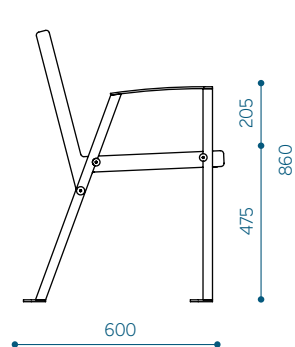



## VARIATIONS

Klaar Wood chair, without armrests -  
KLWB60

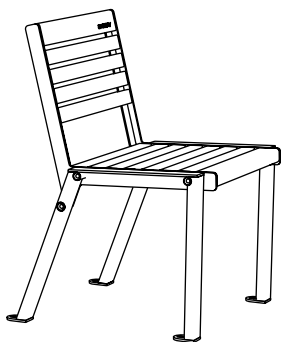

Klaar Wood chair, 2 armrests -  
KLWB60-02



Klaar Wood chair, right armrest -  
KLWB60-04

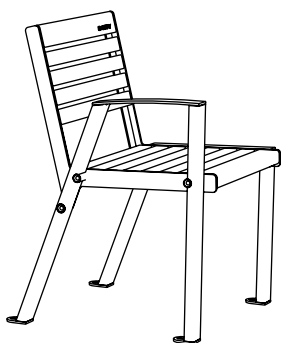

Klaar Wood chair, left armrest -  
KLWB60-05



Material marking in product code:  
a- thermotreated ash  
t- tropical wood

Example of a code use with 2 armrest and  
tropical wood: LKWB60-2-t